

## Solid Carbide Inserts Plaquettes en carbure

### 2 Cutting Edges - FINE GRAIN

#### 1 Hole (up to 25mm)

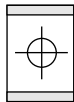

#### 2 Holes (30mm and over)

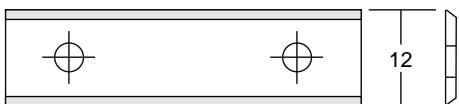
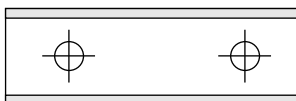

### SUB MICRO GRAIN - (T03SMG) for MDF & laminates

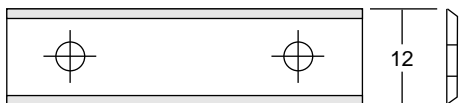

### SUB MICRO GRAIN - (T02SMG) for HDF and other difficult materials

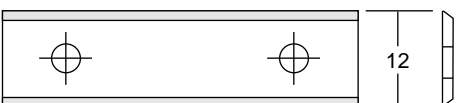

### MICRO GRAIN - for softwoods

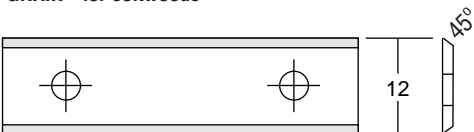

### MICRO GRAIN - for hardwoods

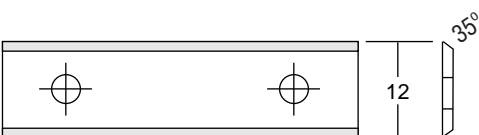

### FLARED for spiral cutterheads

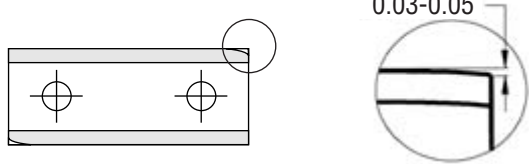

PART NO.	DIMENSIONS
590-0075	7.5 x 12 x 1.5
590-0096	9.6 x 12 x 1.5
590-0105	10.5 x 12 x 1.5
590-0110	11 x 12 x 1.5
590-0130	13 x 12 x 1.5
590-0136	13.6 x 12 x 1.5
590-0150	15 x 12 x 1.5
590-0155	15.7 x 12 x 1.5
590-0200	20 x 12 x 1.5
590-0250	25 x 12 x 1.5
590-0300	30 x 12 x 1.5
590-0350	35 x 12 x 1.5
590-0400	40 x 12 x 1.5
590-0450*	44.5 x 15 x 1.5
590-0500	50 x 12 x 1.5
590-0600	60 x 12 x 1.5
590-0800	80 x 13 x 2.2
590-1000	100 x 13 x 2.2
590-1200	120 x 13 x 2.2

\*OPPOLD

PART NO.	DIMENSIONS
590S-0150	15 x 12 x 1.5
590S-0200	20 x 12 x 1.5
590S-0300	30 x 12 x 1.5
590S-0400	40 x 12 x 1.5
590S-0500	50 x 12 x 1.5
590S-0600	60 x 12 x 1.5
590SM-0150	15 x 12 x 1.5
590SM-0200	20 x 12 x 1.5
590SM-0300	30 x 12 x 1.5
590SM-0400	40 x 12 x 1.5
590SM-0500	50 x 12 x 1.5
590SM-0600	60 x 12 x 1.5

PART NO.	DIMENSIONS
590SS-0200	20 x 12 x 1.5
590SS-0300	30 x 12 x 1.5
590SS-0500	50 x 12 x 1.5

PART NO.	DIMENSIONS
590W-0200	20 x 12 x 1.5
590W-0300	30 x 12 x 1.5
590W-0400	40 x 12 x 1.5
590W-0500	50 x 12 x 1.5
590W-0600	60 x 12 x 1.5

PART NO.	DIMENSIONS
590SP-0200	20 x 12 x 1.5
590SP-0300	30 x 12 x 1.5
590SP-0500	50 x 12 x 1.5

## Solid Carbide Inserts Plaquettes en carbure

### 2 Cutting Edges

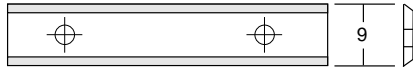

PART NO.	DIMENSIONS
590T-0150	14.6 x 9 x 1.5
590T-0200	20 x 9 x 1.5
590T-0300	30 x 9 x 1.5
590T-0400	40 x 9 x 1.5
590T-0500	50 x 9 x 1.5

### 4 Cutting Edges

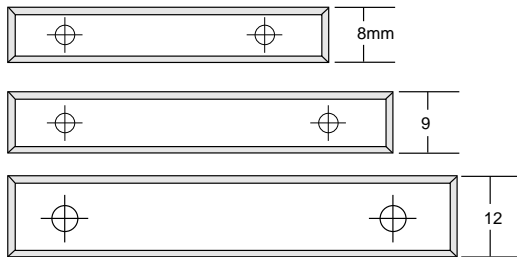

PART NO.	DIMENSIONS
591-2008	20 x 8 x 1.5
591-3008	30 x 8 x 1.5
591-5008	50 x 8 x 1.5
591-2009	20 x 9 x 1.5
591-3009	30 x 9 x 1.5
591-5009	50 x 9 x 1.5
591-2012	20 x 12 x 1.5
591-3012	30 x 12 x 1.5
591-4012	40 x 12 x 1.5
591-5012	50 x 12 x 1.5

### 4 Cutting Edges (square)



PART NO.	DIMENSIONS
591-0909	9 x 9 x 1.5
591-1111	10.5 x 10.5 x 1.5
591-1212	12 x 12 x 1.5 35°
591-1212 45DEG	12 x 12 x 1.5 45°
591-1515	15 x 15 x 2.0
591-1515CB	15 x 15 x 2.0
591-1717	17 x 17 x 2.0
591-1919	19 x 19 x 2.0

### 4 Cutting Edges (Raker for Groovers)



PART NO.	DIMENSIONS
591-1819	18 x 18 x 1.95
591-1824	18 x 18 x 2.45
591-1829	18 x 18 x 2.95
591-1837	18 x 18 x 3.70

### 4 Cutting Edges (spurs) countersunk centre hole

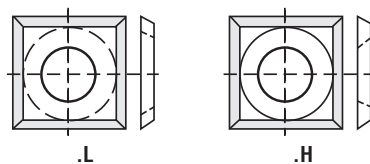

PART NO.	DIMENSIONS
592-1313.0	13.0 x 13.0 x 2.5 (O)
592-1313	13.6 x 13.6 x 2.0
592-1414.L	14.0 x 14.0 x 1.2 (L)
592-1414.H	14.0 x 14.0 x 1.2 (H)
592-1414	14.0 x 14.0 x 2.0
592-143143	14.3 x 14.3 x 2.5
592-146146	14.6 x 14.6 x 2.5
592-1515	15.0 x 15.0 x 2.5

O = Oppold      L = Lamello      H = Holz-Her

### Miscellaneous Spurs

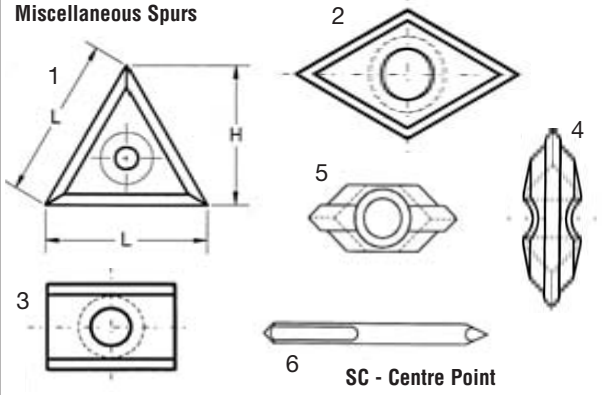

PART NO.	DIMENSIONS	#
592-0001	22 x 19 x 2.0	1
592-0002	14 x 14 x 2.0	2
592-0003	20 x 14.3 x 2.5	3
592-0004	Leuco System	4
592-0005	Howema System	5
592-0006	Leuco System	6

## Solid Carbide Inserts Plaquettes en carbure

Special eased edge knives  
for spiral planer heads  
4 Cutting Edges

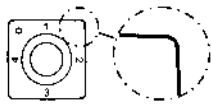

PART NO.	DIMENSIONS
592-0007E	15 x 15 x 2.5

Special eased edge knives  
straight with rounded edges  
for spiral planer heads  
4 Cutting Edges



PART NO.	DIMENSIONS
592-0009	15 x 15 x 2.5

Reich - Holz-Her  
Trim Knives  
15° Bevel  
Back of knife shown

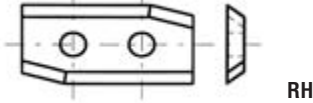

PART NO.	DIMENSIONS
593-H30L	30 x 12 x 1.5 LH
593-H30R	30 x 12 x 1.5 RH

"V" Groove Knives  
5° Bevel

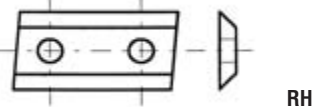

PART NO.	DIMENSIONS
593-V30L	30 x 12 x 1.5 LH
593-V30R	30 x 12 x 1.5 RH
593-V50L	50 x 12 x 1.5 LH
593-V50R	50 x 12 x 1.5 RH

## Mini-Turnover Knives / Mini couteaux réversibles

2 Cutting Edges - Back Groove



PART NO.	DIMENSIONS
594B-1255	12 x 5.5 x 1.1
594B-2055	20 x 5.5 x 1.1
594B-3055	30 x 5.5 x 1.1
594B-5055	50 x 5.5 x 1.1

4 Cutting Edges - Back Groove

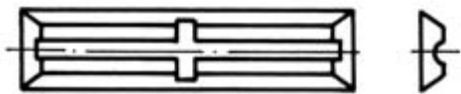

PART NO.	DIMENSIONS
594L-2041	20 x 4.1 x 1.1
594L-2055	20 x 5.5 x 1.1
594L-3055	30 x 5.5 x 1.1
594L-4055	40 x 5.5 x 1.1
594L-5055	50 x 5.5 x 1.1

2 Cutting Edges - Face Groove



PART NO.	DIMENSIONS
594F-1255	12 x 5.5 x 1.1
594F-2055	20 x 5.5 x 1.1
594F-3055	30 x 5.5 x 1.1
594F-3955*	39.8 x 5.5 x 1.1
594F-4055	40 x 5.5 x 1.1
594F-5055	50 x 5.5 x 1.1
594F-1280	11.7 x 8.0 x 1.5
594F-1580	14.7 x 8.0 x 1.5
594F-2080	19.7 x 8.0 x 1.5
594F-3080	30 x 8.0 x 1.5

4 Cutting Edges - Bevel End

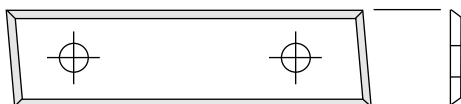

Back of knife shown

RH

PART NO.	DIMENSIONS
595-3090L	30 x 9.0 x 1.5 LH
595-3090R	30 x 9.0 x 1.5 RH
595-4090L	40 x 9.0 x 1.5 LH
595-4090R	40 x 9.0 x 1.5 RH
595-5090L	50 x 9.0 x 1.5 LH
595-5090R	50 x 9.0 x 1.5 RH
595-2012L	20 x 12.0 x 1.5 LH
595-2012R	20 x 12.0 x 1.5 RH
595-3012L	30 x 12.0 x 1.5 LH
595-3012R	30 x 12.0 x 1.5 RH
595-4012L	40 x 12.0 x 1.5 LH
595-4012R	40 x 12.0 x 1.5 RH
595-5012L	50 x 12.0 x 1.5 LH
595-5012R	50 x 12.0 x 1.5 RH

**Solid Carbide Inserts**  
**Plaquettes en carbure**

2 Cutting Edges - "Versafix" Titanium Coated

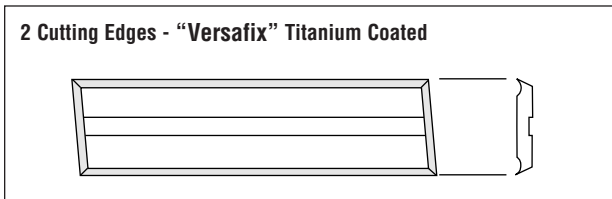

PART NO.	DIMENSIONS
595G-2055	20 x 5.5 x 1.1
595G-3065	30 x 6.5 x 1.1
595G-3010	30 x 10 x 1.5
595G-5010	50 x 10 x 1.5

Also available without titanium coating on request.  
Use part number 595S-...

*Les plaquettes sont également disponibles sans revêtement de titane sur demande. Utiliser le nombre 595S-...*

**Mini-Turnover Knives for Portable Planers**  
**Mini couteaux réversibles pour rabots portatifs**

2 Cutting Edges - Back Groove

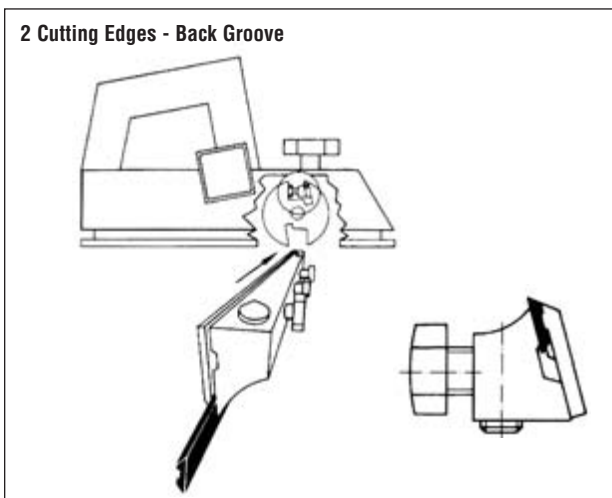

PART NO.	DIMENSIONS
596-5655	56 x 5.5 x 1.1 "Adler"
596-6055	60 x 5.5 x 1.1 "Wegoma"
596-7555	75.5 x 5.5 x 1.1 "AEG, Bosch, Festo, Haffner, Kress, Mafell, Metabo, Scheer, Skil, Holz-Her"
596-8059	80.5 x 5.9 x 1.1 "Elu"
596-8255	82 x 5.5 x 1.1 "AEG, B&D, Bosch, ALU, Fein, Felisatti, Haffner Hitachi, Holz-Her, Mafell, Makita, Metabo, Peugeot, Ryobi, Skil"

**Carbide Reversible Knives for Garniga® -**  
**"BULLDOZER" Planer Head**  
**Couteaux réversibles en carbure pour Garniga -**  
**« BULLDOZER » raboteuse**

2 Cutting Edges

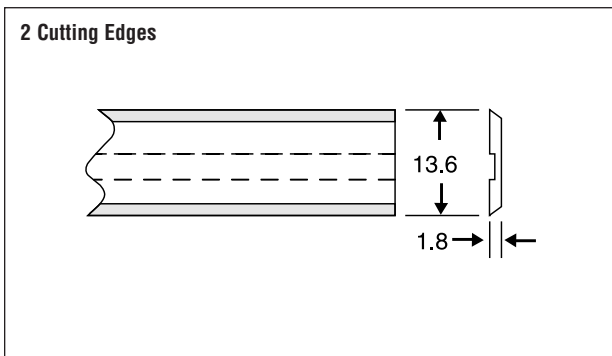

PART NO.	DIMENSIONS
598-100HM	100 x 13.6 x 1.8
598-120HM	120 x 13.6 x 1.8
598-130HM	130 x 13.6 x 1.8
598-150HM	150 x 13.6 x 1.8
598-180HM	180 x 13.6 x 1.8
598-200HM	200 x 13.6 x 1.8
598-230HM	230 x 13.6 x 1.8
598-250HM	250 x 13.6 x 1.8

## Miscellaneous Bevel & Radius Knives

Divers couteaux à ébarber des rayons et des angles

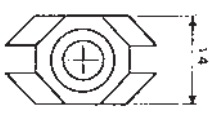
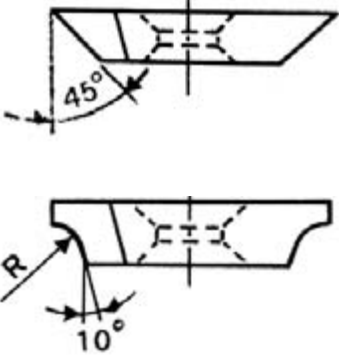
TYPE / MODÈLE		
	<b>PART NO.</b>	<b>PART NO.</b>
	599A-1.5R 16.0 x 22.0 x 5.0	599B-1.5R
	599A-2.0R 16.0 x 22.0 x 5.0	----
	599A-2.5R 16.0 x 22.0 x 5.0	----
	599A-3.0R 16.0 x 22.0 x 5.0	599B-3.0R
	599A-4.0R 16.0 x 22.0 x 5.0	599B-45
	599A-45 16.0 x 22.0 x 5.0	599B-45
	599A-5.0R 16.0 x 22.0 x 5.0	----

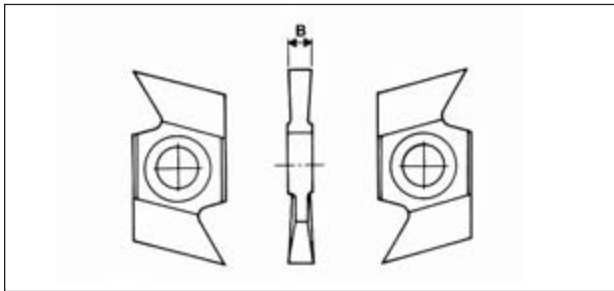

PART NO.	B
599C-025	2.5 x 34
599C-030L	3 x 34
599C-030R	3 x 34
599C-035	3.5 x 36
599C-040	4 x 37
599C-050	5 x 37
599C-060	6 x 37

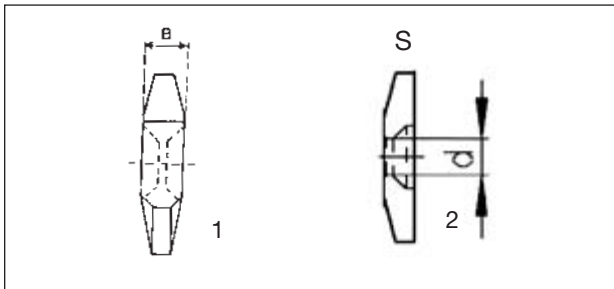

PART NO.	#	B
599D-050	1	3 x 5 x 37
599D-060	1	3.4 x 6 x 31
599D-025	2	2.5 x 2W

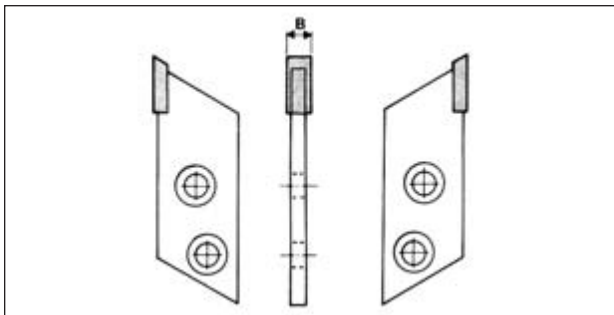

PART NO.	B
599E-030L	3 x 44
599E-030R	3 x 44
599E-040	4 x 44
599E-050	5 x 44
599E-060	6 x 44
599E-080	8 x 44

**Solid Carbide Profiled Turnover Knives**  
**Plaquettes réversibles profilées en carbure**

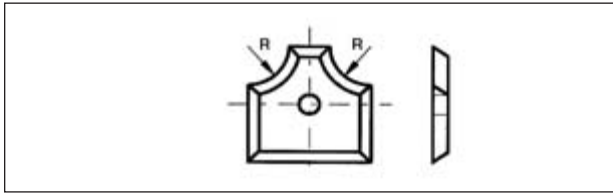

**System: HOLZ-HER**

PART NO.	L	W	T	Rad	Hole
600-002	12	12	1.5	2	4mm
600-003	12	12	1.5	3	4mm
600-004	12	12	1.5	4	4mm

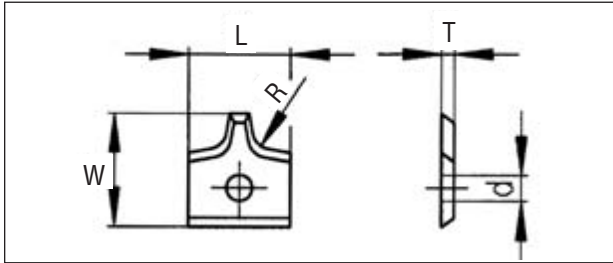

**System: HOMAG/IMA**

PART NO.	L	W	T	Rad	Hole
602-002	16	17.5	2.0	2	4mm
602-003	16	17.5	2.0	3	4mm
602-003A	16	17.5	2.0	3	3.5mm
602-004	16	17.5	2.0	4	4mm
602-005	16	17.5	2.0	5	4mm
602-006	16	17.5	2.0	6	4mm

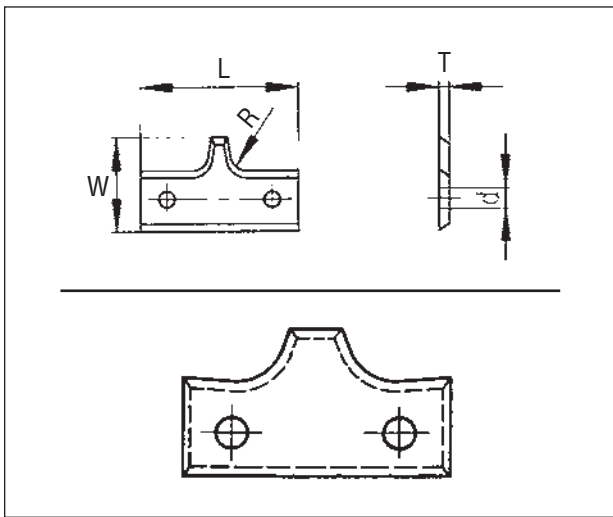

**System: HOMAG**

PART NO.	L	W	T	Rad	Hole
604-002	20.8	15	2.0	2	4mm
604-003	20.8	15	2.0	3	4mm
604-004	20.8	15	2.0	4	4mm
604-005	30.0	17	2.0	5	4mm
604-006	30.0	17	2.0	6	4mm
604-007	30.0	17	2.0	7	4mm
604-008	30.0	17	2.0	8	4mm

**System: IMA**

PART NO.	L	W	T	Rad	Hole
606-005	30.5	16.5	2.0	5	4mm
606-006	30.5	16.5	2.0	6	4mm
606-007	30.5	16.5	2.0	7	4mm
606-008	30.5	16.5	2.0	8	4mm

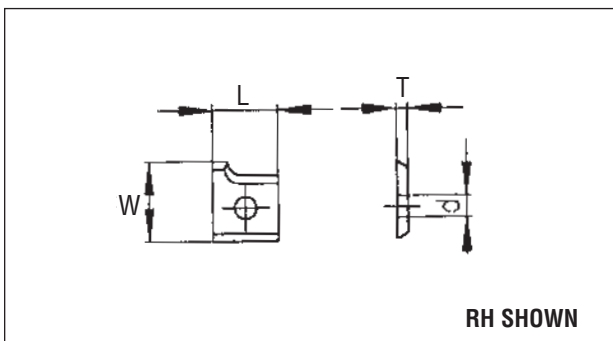

PART NO.	L	W	T	Rad	Hole
608-002L	12	14.5	2.0	2	4mm
608-002R	12	14.5	2.0	2	4mm
608-025L	12	14.5	2.0	2.5	4mm
608-025R	12	14.5	2.0	2.5	4mm
608-003L	12	14.5	2.0	3	4mm
608-003R	12	14.5	2.0	3	4mm
608-019L	19.6	15.2	2.0	2	4mm
608-019R	19.6	15.2	2.0	2	4mm
608-021L	19.6	15.2	2.0	3	4mm
608-021R	19.6	15.2	2.0	3	4mm

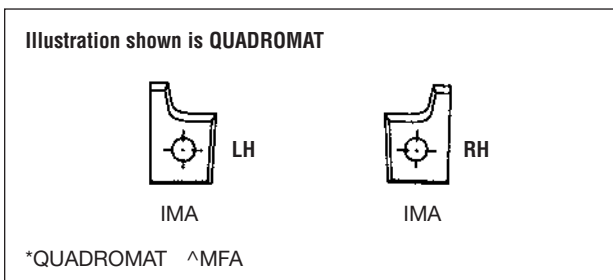

PART NO.	L	W	T	Rad	Hole
610-002L *	12	18	2.0	2	4mm
610-002R *	12	18	2.0	2	4mm
610-003L ^	12	18	2.0	3	4mm
610-003R ^	12	18	2.0	3	4mm
610-028L *	12	18	2.0	3	4mm
610-028R *	12	18	2.0	3	4mm
610-029L ^	12	18	2.0	2	4mm
610-029R ^	12	18	2.0	2	4mm

**Solid Carbide Profiled Turnover Knives**  
*Plaquettes réversibles profilées en carbure*

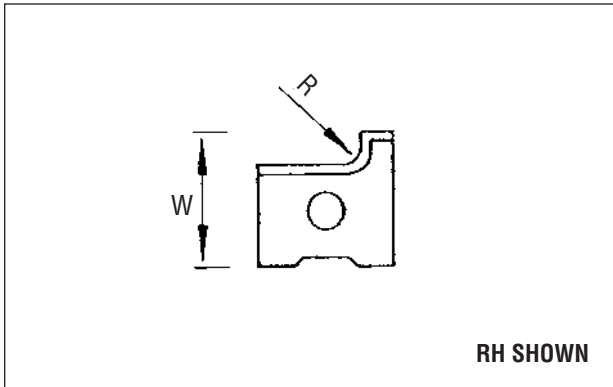

PART NO.	L	W	T	Rad	Hole
612-002L	15	14.5	2.0	2	4mm
612-002R	15	14.5	2.0	2	4mm
612-025L	15	14.5	2.0	2.5	4mm
612-025R	15	14.5	2.0	2.5	4mm
612-003L	15	14.5	2.0	3	4mm
612-003R	15	14.5	2.0	3	4mm
612-004L	16.1	14.0	2.0	2	5mm
612-004R	16.1	14.0	2.0	2	5mm
612-005L	16.1	14.0	2.0	3	5mm
612-005R	16.1	14.0	2.0	3	5mm

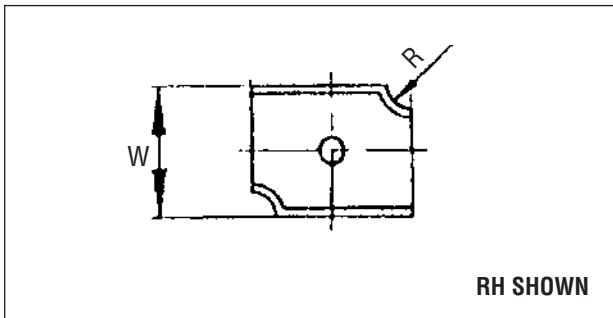

PART NO.	L	W	T	Rad	Hole
614-003L	20	16	2.0	3	3mm
614-003R	20	16	2.0	3	3mm
614-002L	30	14	2.0	2	4mm
614-002R	30	14	2.0	2	4mm
614-025L	30	14	2.0	2.5	4mm
614-025R	30	14	2.0	2.5	4mm
614-030L	30	14	2.0	3	4mm
614-030R	30	14	2.0	3	4mm

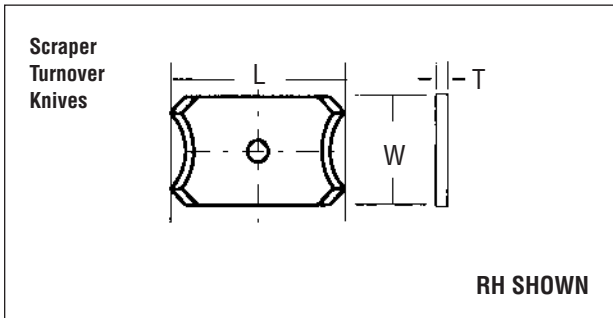

PART NO.	L	W	T	Rad	Hole	A°
616-001	20	12	2.0	1	4mm	6
616-002	20	12	2.0	2	4mm	6
616-003	20	12	2.0	3	4mm	6
616-004	20	12	2.0	4	4mm	6
616-005	20	12	2.0	5	4mm	6
616-006	20	12	2.0	1	4mm	15
616-007	20	12	2.0	2	4mm	15
616-008	20	12	2.0	3	4mm	15

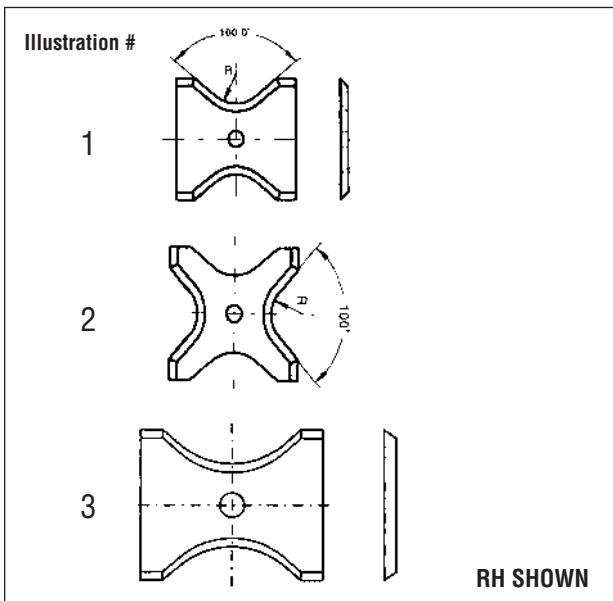

**System: LEUCO**

PART NO.	L	W	T	Rad	Hole	#
618-002	13	16	2.0	2	4mm	1
618-003	13	16	2.0	3	4mm	1
618-004	13	16	2.0	4	4mm	1
618-005	20	21	2.0	5	4mm	2
618-006	20	21	2.0	6	4mm	2
618-007	20	21	2.0	7	4mm	2
618-008	20	21	2.0	8	4mm	2
618-009	26	24	2.0	9	4mm	2
618-010	26	24	2.0	10	4mm	2
618-011	26	24	2.0	11	4mm	2
618-012	26	24	2.0	12	4mm	2
618-013	26	24	2.0	13	4mm	2
618-014	30	25	2.0	14	4mm	3
618-015	30	25	2.0	15	4mm	3
618-016	30	25	2.0	16	4mm	3

**Solid Carbide Profiled Turnover Knives**  
*Plaquettes réversibles profilées en carbure*

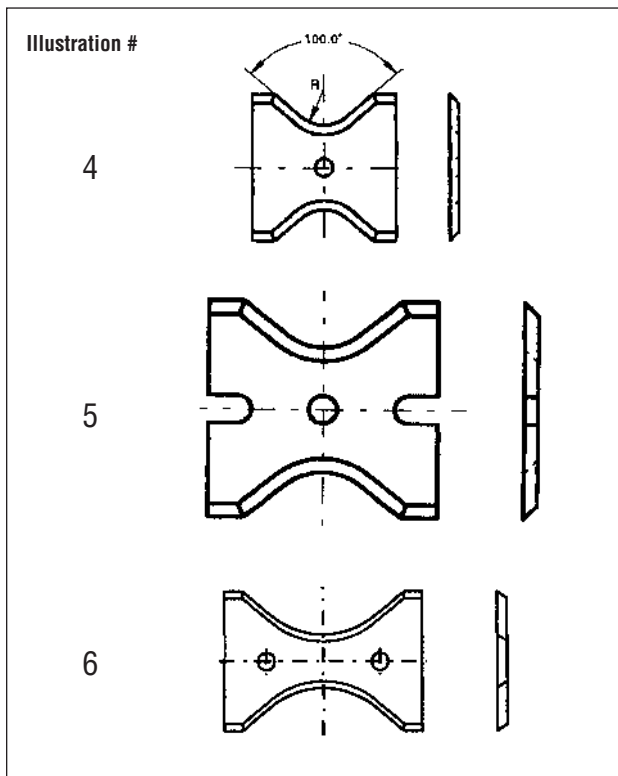

**System: HOWEMA**

PART NO.	L	W	T	Rad	Hole	#
620-002	13	14	1.5	2	3.2	4
620-003	13	14	1.5	3	3.2	4
620-004	13	14	1.5	4	3.2	4
620-005	20	16	2.0	5	3.2	5
620-006	20	16	2.0	6	3.2	5
620-007	20	16	2.0	7	3.2	5
620-008	20	16	2.0	8	3.2	5
620-009	26	18	2.0	9	3.2	5
620-010	26	18	2.0	10	3.2	5
620-011	26	18	2.0	11	3.2	5
620-012	26	18	2.0	12	3.2	5
620-0125	26	18	2.0	12.5	3.2	5
620-013	30	20	2.0	13	3.2	5
620-014	30	20	2.0	14	3.2	5
620-015	30	20	2.0	15	3.2	5
620-016	30	20	2.0	16	3.2	5
620-017	40	28	2.0	17	3.2	6
620-018	40	28	2.0	18	3.2	6
620-019	40	28	2.0	19	3.2	6
620-020	40	28	2.0	20	3.2	6

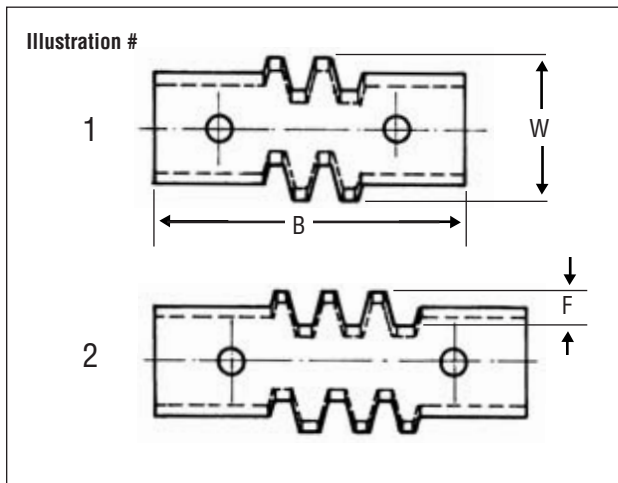

**Glue Joint Knives - Double Profile**

PART NO.	L	W	T	F	Illust. #
625-002	50	21.6	2.0	5	1
625-003	60	22.8	2.0	5	2
625-004	60	18.0	2.0	3	3

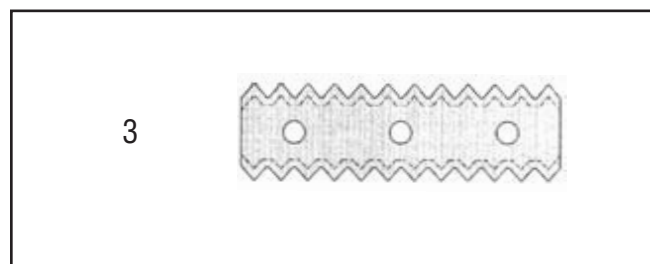

**Solid Carbide Multi-Profiler Blank Inserts and Backing Plates**  
**Plaquettes brutes Multi-Profiler en carbure et plaquettes d'appui**

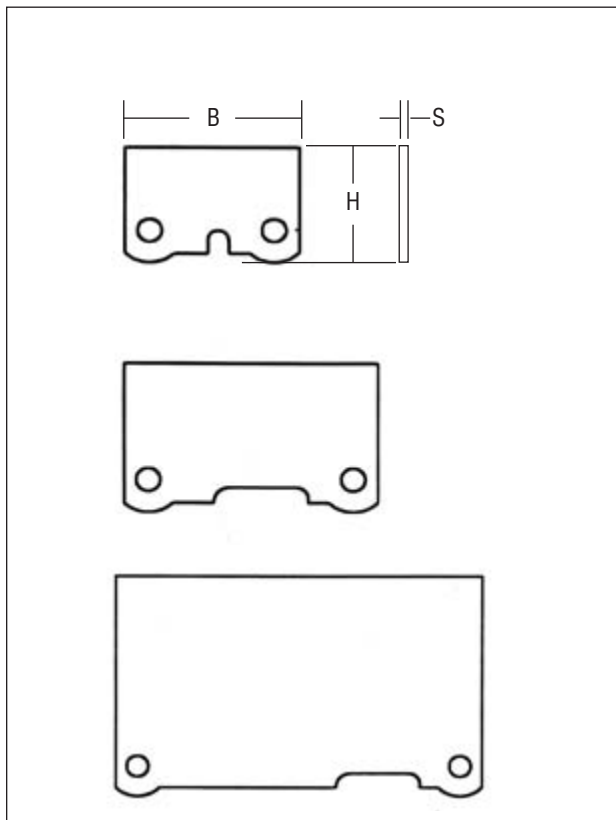

**Inserts for Leuco-Super-Profiler System**  
**Plaquettes pour Leuco-Super-Profiler System**

PART NO.	B	H	S
630-3126	31	26	1.5
630-4128	41	28	1.5
630-5135	51	35	1.5
630-6131	61	31	1.5
630-6145	61	45	2.0
630-8145	81	45	2.0

**Backing Plates for Leuco-Super-Profilers**  
**Plaquettes d'appui pour Leuco-Super-Profiler**

PART NO.	B	H	S
630B-3126	31	26	4
630B-4128	41	28	4
630B-5135	51	35	4
630B-6131	61	31	4
630B-6145	61	45	4
630B-8145	81	45	4

*C4 Grade Carbide inserts supplied unless specified otherwise.*

*Pins = 583-PIN.3x8*

**Blank Inserts / Backer Plates - Series #632-0000**  
**Plaquettes Brutes / plaquettes d'appui - Series #632-000**

We also offer a wide variety of inserts and backer plates for other manufacturers cutterheads.

*Nous offrons également une grande variété de plaquettes et de plaquettes d'appui pour d'autres fabricants de porte-outils.*

**TC one-way profile knives with single edged profile**

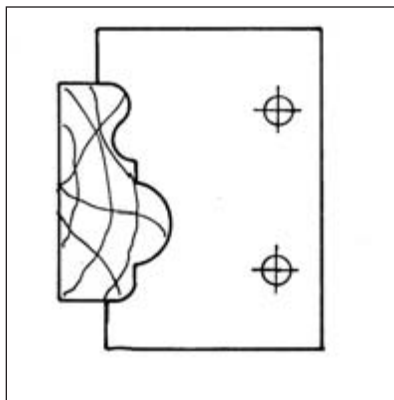

**TC turnover profile knives with double edged profile**

